

- |   |   |   |   |
|---|---|---|---|
| 1 | 2 | 3 | 4 |
| 5 | 6 | 7 |   |

160°

127°

200t/h

30%

1/2-

1/3

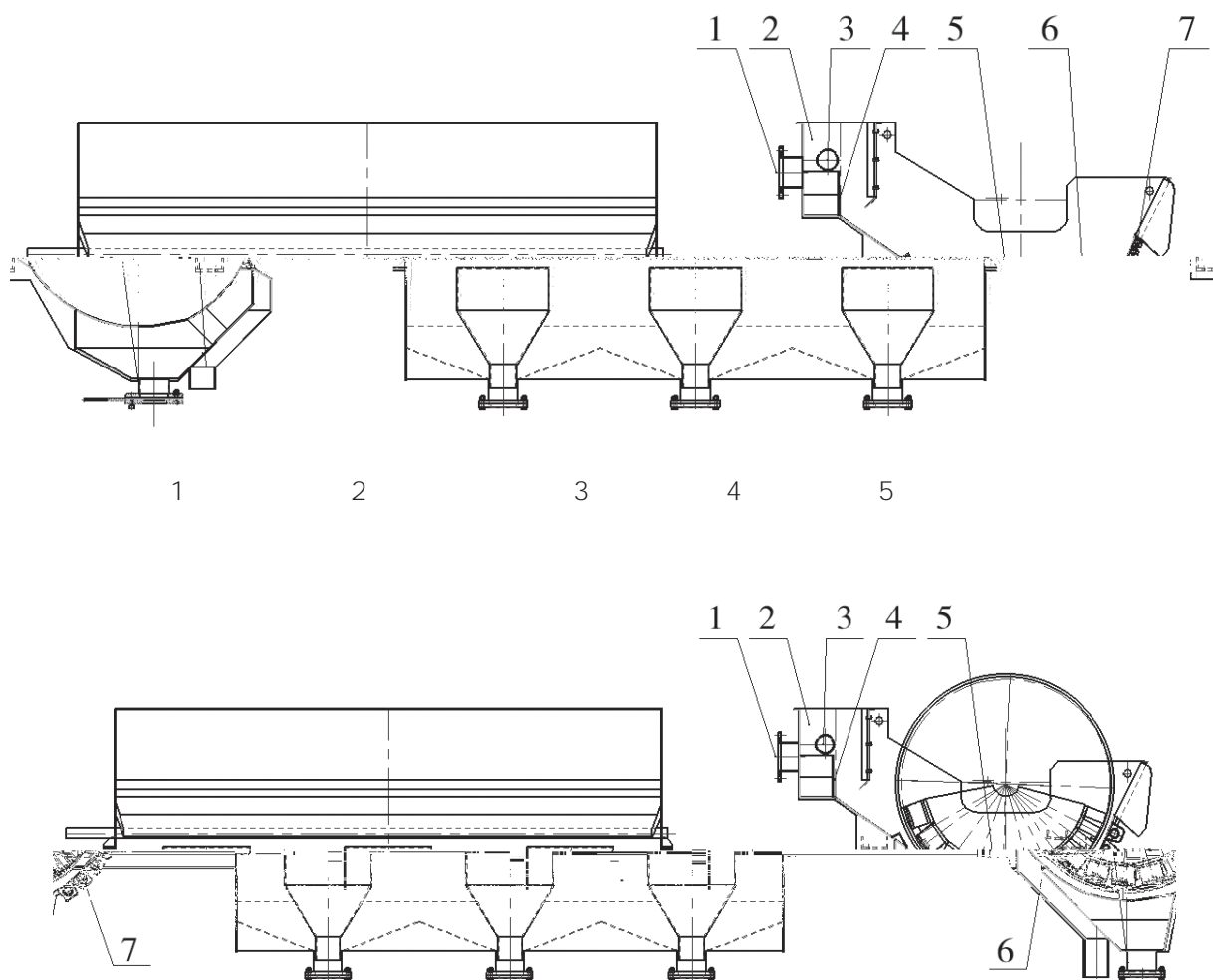

此 处 留 白

	× mm	mT	t/h	kW	dB(A)	(t)
TCTJ- 1015	1050× 1500	180- 700	35- 50	5. 5	70	3. 5
TCTJ- 1018	1050× 1800		45- 60			4. 0
TCTJ- 1021	1050× 2100		50- 70			4. 5
TCTJ- 1024	1050× 2400		60- 80	11		5. 2
TCTJ- 1030	1050× 3000		80- 120			6. 7
TCTJ- 1224	1200× 2400		70- 110			7. 5
TCTJ- 1230	1200× 3000		90- 130			9. 2
TCTJ- 1236	1200× 3600		110- 150			9. 85
TCTJ- 1240	1200× 4000		120- 160			11. 5
TCTJ- 1245	1200× 4500		130- 170	12. 3		
TCTJ- 1530	1500× 3000		140- 180	12. 8		
TCTJ- 1540	1500× 4000		150- 190			15
TCTJ- 1545	1500× 4500		160- 220	22		16. 5
TCTJ- 1550	1500× 5000		180- 260			18

( )

